

STI Stopper® II Heated Enclosure



STI-1200A-HTR



PRODUCT OVERVIEW

The Stopper II is a patented device that has been helping stop false fire alarms around the world for more than 25 years, without restricting legitimate alarms. This Stopper II enclosure with heater allows addressable dual monitor modules to be installed inside or outside in temperatures below UL Listing limits or in other NEMA 3R environments. UL/cUL Listing requires outdoor rated stations. The cover offers excellent protection against physical damage (both accidental and intentional), as well as other environments inside and outside. Also ideal for inside of walk-in freezers.

HOW IT WORKS

Stopper II Heated Enclosure consists of a clear, super tough polycarbonate shield, frame and heater. The Stopper II is mounted on a NEMA 3R enclosure with a heater which allows an addressable manual pull station to be installed inside or outside in cold temperatures.

FEATURES

- For use in areas where temperature or environmental conditions exceed the operational range of UL Listed devices.
- Heater unit cycles as required to maintain the correct range of operating temperatures.
- Fan runs continuously to maintain a uniform temperature inside the enclosure.
- The thick, clear polycarbonate cover is UV-stabilized against discoloration.
- Typical working properties of polycarbonate are -40° to 250°F (-40° to 121°C).
- UL Listed to U.S. and Canadian safety standards. See reverse side for details.
- Maintains operating temperature with external temperatures to -70°F (-57°C).
- Enclosure rated to NEMA 3R Standards.
- UL Listing does not require standby or secondary power for 110 or 140 VAC 60 Hz heater.
- UL/cUL Listing requires outdoor rated stations.
- Lifetime guarantee against breakage of polycarbonate in normal use (one year on electro mechanical and electronic components).

STI Stopper® II Heated Enclosure

Dimensions and Technical Information

MODELS AVAILABLE

STI-1200A-HTR With 4 in. deep backbox - 110 VAC
STI-1200A-HTR240 With 4 in. deep backbox - 240 VAC

Accessory

STI-HK3 Replacement heater

SPECIFICATIONS

INTERNAL DIMENSIONS:

PART #	HEIGHT	WIDTH	DEPTH
1200A-HTR	6.25 in.	4.125 in.	1.25 in.
1220A-HTR240	(158mm)	(104mm)	(31mm)

POLYCARBONATE ENCLOSURE:

Flammability: UL94 V-2
 Wall Thickness: backbox: .20 inches (5.1mm)
 cover: .12 inches (3.1mm)
 NEMA Rating: 3R
 Warranty: Lifetime against breakage in normal use (one year on electronics from time of installation)

SILICONE LAMINATE HEATER:

STI-1200A-HTR 110 VAC 50/60 Hz UL Recognized Component
 STI-1200-A-HTR240 240 VAC 50/60 Hz UL Recognized Component
 100 Watts
 Life: @ -10°C (14°F) ~ 70°C (158°F) 5 years
 Duty Cycle: -40°F (-40°C) 16%
 -70°F (-57°C) 38%
 -99°F (-73°C) 100%

FAN:

24 VDC (±10%), 90 mA UL Recognized Component
 Life: 5 years continuous duty
 WARNING: The polarity of the circulating fan is important as it only rotates in one direction with red lead being positive.

GASKET:

Material: Neoprene
 Life: 5 Years

APPROVALS & WARRANTY

TESTING

It has been tested and approved or listed by:
 · UL, cUL Listed S2466 (requires outdoor rated station)
 · UL File S7025 is cross referenced to File S2466 permitting STI Stopper® Stations, non fire, in category UEHX and Listed to UL 2017 for outdoor use
 · ADA Compliant

WARRANTY

Lifetime guarantee against breakage of polycarbonate in normal use (one year on electro mechanical and electronic components).

WARNINGS

The enclosure is used to protect UL Listed 38 and 2017 manual initiating outdoor listed devices at temperatures down to -70°F (-57°C). It is the installer's responsibility to comply with NEC 70 Articles 725 and 760, NFPA 72, and other applicable fire and electrical codes. Conduit or raceway paths need to be sealed as near to the enclosure as possible. Installer should have maintained supervision over the low temperature thermostat. The low temperature monitoring thermostat makes the circuit at +32°F (0°C) and clears the circuit at +50°F (+10°C). This listing requires that the fire alarm supervisory control module be only of the latching type. On the appliance mounting plate is a label where you should record the installation date. Also includes serial number and installation date on the instruction sheet for quick reference.

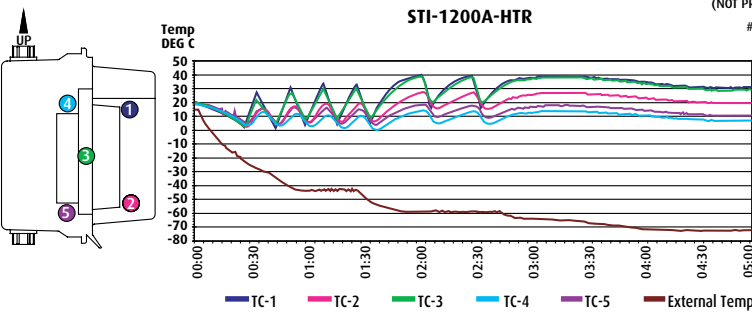
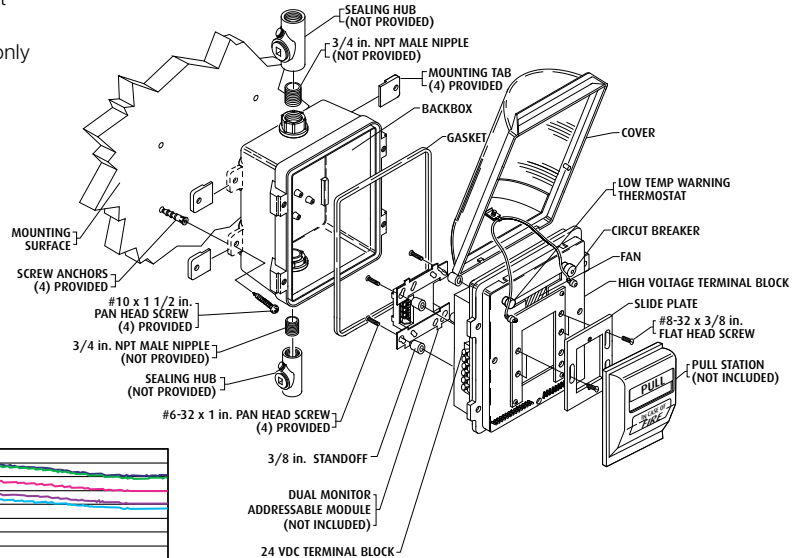

Safety Technology International, Inc.

2306 Airport Road
 Waterford, Michigan
 48327, USA

Tel: 248-673-9898
 Fax: 248-673-1246
 Tollfree: 800-888-4784
 info@sti-usa.com
 www.sti-usa.com

Unit 49G Pipers Road
 Park Farm Industrial Estate
 Redditch, Worcestershire
 B98 0HU England

Tel: 44 (0) 1527 520 999
 Fax: 44 (0) 1527 501 999
 Free: 0800 085 1678 (UK)
 www.sti-europe.com